

Traditional seat of solid wood.



Pressalit Selandia, incl. B47 universal hinge

No. 522xxx-B47 with cover

Design/Year

Pressalit, 1996

Product Description

PRESSALIT toilet seat with cover, model "Selandia", art. no. 522 of solid wood with stainless steel hinges.
 - with B47 universal hinge of stainless steel
 - centre distance: 120 - 170 mm
 - birch
 - load - ring seat 240 kg
 - 10 year guarantee

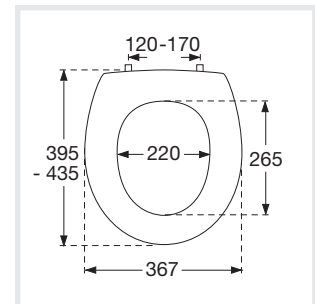

Colour Programme xxx

455 mahogany (stained birch), 456 cherry (stained birch), 607 natural birch

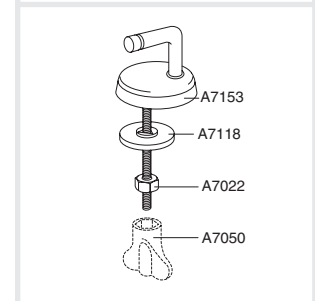

Alternative Hinge

BH5 Top mounted hinge

Hinge Finishes

999 Stainless steel

Spare Parts

A4003 Buffer for pushing into cover, round, grey, A4003031 brown
 A4011 Buffer for pushing into seat, oval, grey, A4011031 brown
 A7222 Clamp bush, grey
 A9137 Set of straps and screws, stainless steel

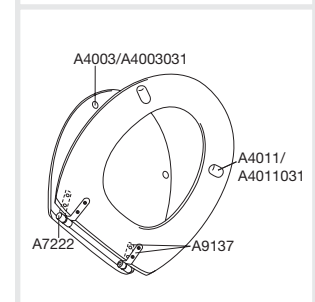

Seats for your senses

Product Weight

Net weight approx. 2,800 kg, incl. hinge

Packaging

Single carton
 5 single cartons in a master carton
 18 master cartons (90 seats) on a pallet

Dimensions:

449x381x64 mm
 456x388x340 mm

Weight:

3,100 kg
 16,000 kg

Material Description**TOILET SEAT:**

(455) birch, mahogany coloured (coloured pigment in lacquer)
 (456) birch, cherry coloured (coloured pigment in lacquer)
 (607) birch

Surface: 3 x acid-hardened transparent lacquer.

BUFFERS:

EVA (copolymer made of ethylene and vinyl acetate).

HINGE LINKS:

Stainless steel (V2A) model W. no. 1.4301/M in accordance with DIN 17441/85.

Composition: chrome (cr) 17-19%, nickel (ni) 8-11%, carbon <0.05%, molybdenum, manganese, silicone, sulphur, titanium.

MOUNT/HINGES:

Stainless steel (V2A) model W. no. 1.4301/M in accordance with DIN 17441/85.

Composition: chrome (cr) 17-19%, nickel (ni) 8-11%, carbon <0.05%, molybdenum, manganese, silicone, sulphur, titanium.

Suitability List

Usable on universal toilets - see the printed seat suitability specifications.

Cleaning Instructions

Use a mild soap solution. Seat and hinges should not be left damp, but be dried with a soft cloth. It is important that the surface lacquer is kept intact, so that the wood itself does not get in direct contact with water. When using abrasive, corrosive or chlorine based cleaners for the bowl, avoid contact with seat and hinges. Therefore, when cleaning the bowl, make sure that seat and cover are in an upright position until all the cleaner has been flushed away.

The guarantee includes faults or defects in the material of our products within a period of 10 years.
 Products subject to minor technical modifications and design deviations E. & O.E.



Pressalit A/S, Denmark

www.pressalit.com

European Sales Agencies
 Leith House, 39 Campion Drive
 Tanfield Lea, Stanley
 Co. Durham. DH9 9PQ
 Tel.01207 236622, Fax 01207 236633
 info@europeansalesagencies.com
 www.europeansalesagencies.com

Pressalit A/S
 Pressalitvej 1
 DK-8680 Ry
 Tel. (+45) 8788 8788
 Fax (+45) 8788 8789
 pressalit@pressalit.com
 - a division of Pressalit Group A/S



Seats for your senses